

BATT PACK

User Manual

Manufactured by:
**HYBRID
POWER
SOLUTIONS**

288 Judson St #5
ON M8Z 5T6

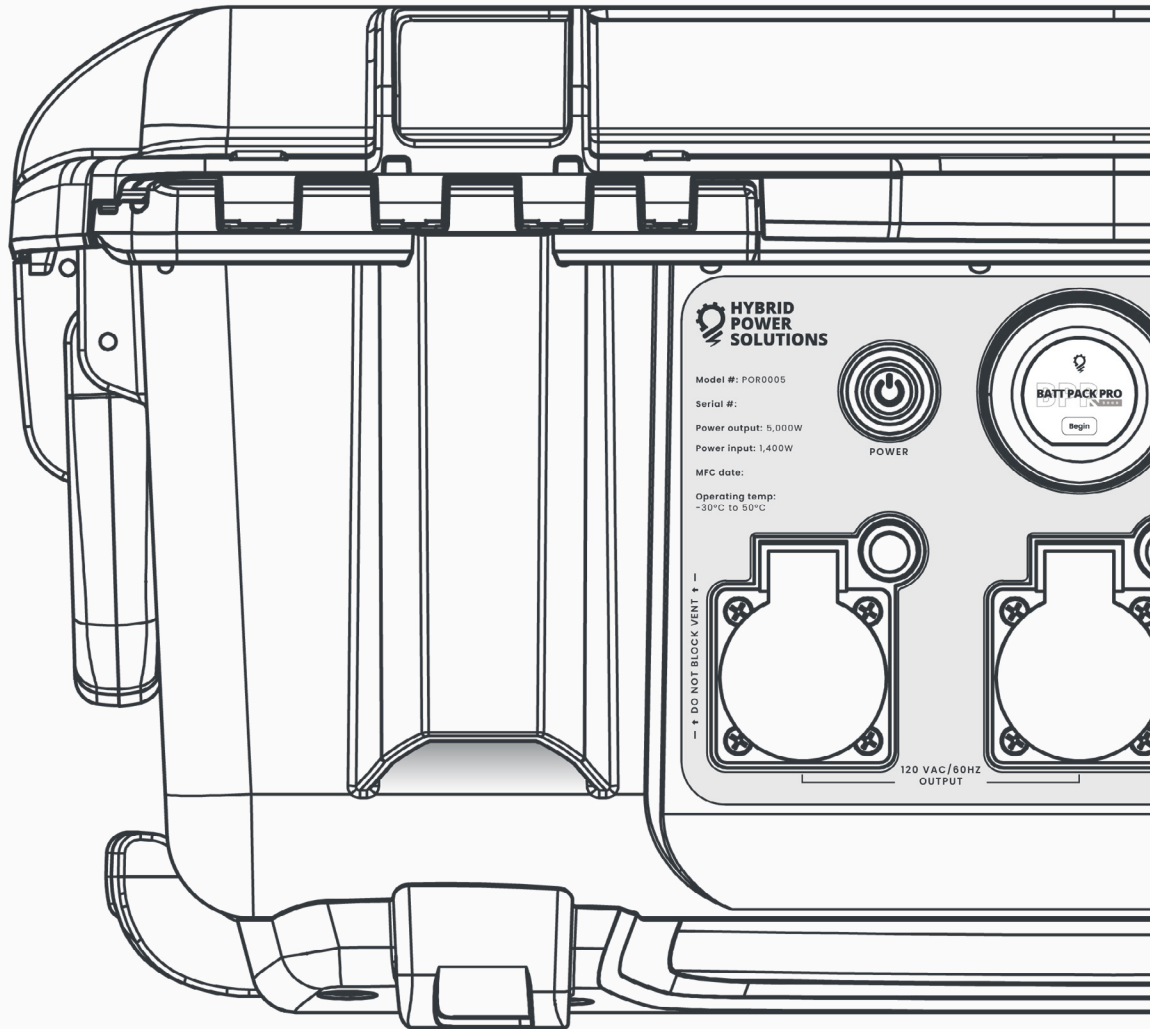

**HYBRID
POWER
SOLUTIONS**

Model #: POR0005

Serial #:

Power output: 5,000W

Power input: 1,400W

MFC date:

Operating temp:
-30°C to 50°C

↑ DO NOT BLOCK VENT ↓

120 VAC / 60HZ
OUTPUT



[This page intentionally left blank]

BATTPACK

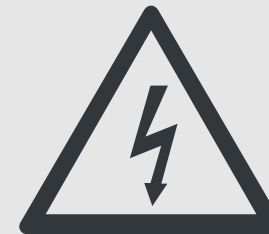

SHOCK HAZARD:

Possible shock or death if used improperly, when damaged or used by untrained personnel.



FLAMMABLE HAZARD:

Lithium ion batteries contain flammable liquid electrolyte that may vent, ignite and produce sparks when subjected to high temperatures (> 150 °C (302 °F)), when damaged or abused (e.g., mechanical damage or electrical overcharge). Burning cells can ignite other batteries in close proximity.

Vapors or mists from a ruptured battery may cause respiratory irritation.

Manual **INDEX**

Content	Page
Introduction	08
Safety Information	10
Configuration	13
Operation	27
Solar Panel Purchasing + Wiring Guide	32
Hardwire Instructions for Backup Power	38
Troubleshoot	40
Multipurpose DC Input Manual	42
Warranty	47

INTRODUCTION

Section 1

1.1. Product Description

Thank you for choosing this portable power supply from Hybrid Power Solutions (HPS). We hope you enjoy and use the Batt Pack to its full potential.

Please unpack your Batt Pack carefully and check the delivery for completeness and obvious damage. In case of damage inform us immediately.

The Batt Pack is delivered to you in a ready to use state with 30% energy (+/-5%). However, please make sure you read through this user manual carefully. If you have further questions regarding the Batt Pack, please contact HPS.

Our Batt Packs are assembled in Canada with domestic and imported parts.

1.2. Contact Details

Hybrid Power Solutions Inc.
288 Judson St Unit #5,
Toronto, ON M8Z 5T6
Canada

Technical Support: +1 (289) 633-5055

Sales: +1 (866) 549-2743

E-Mail: Info@hybridps.ca

Website: hybridps.ca

2.1. General Safety Instructions

Before operating the Batt Pack, carefully read and fully understand the instructions including all the cautions and safety notices shown on the second page of this manual. Following all instructions for proper operation and troubleshooting will reduce the risk of personal injury, death and/or property damage.

These instructions are not intended as a complete list of all details for operating and troubleshooting, although reading and following them will aim to keep you safe. If you have any questions or concerns about procedures or safety that are not covered by these instructions, do not hesitate to contact HPS.

2.2. Operator Responsibility

Treat the Batt Pack system with general care, by closing the output plugs and input plugs and turning the system off when not in use.

If an unfamiliar sound or smell is noted to come from the unit, please turn off the unit and notify HPS immediately. Leave in a well-ventilated area, away from flammable sources.

WARNING: Do not put fingers and/or any other object into the units plugs.

Never open the unit case.

Do not expose to temperatures outside the range of -30°C to 50°C.

To minimize any adverse effects on battery performance it is recommended that the system be kept at room temperature (20°C +/- 5°C). Low or elevated temperatures can result in shortened cell life.

Keep out of reach of children.

GFCI WARNING: Although the Batt Pack does have circuit interruption built into the design, we highly recommend the use of a GFCI adapter in certain situations. This adapter can be supplied by HPS or other reputable suppliers. We do not include a GFCI as the Batt Pack may be used in various scenarios that either do, or do not require this device. The following is a general outline from the National Electrical Code (NEC). Please review the entire NEC documentation pertaining to this matter to help with your decision-making process.

CONFIGURATION

Section 3

Commercial GFCI Requirements (NEC 2014 Excerpt)

- All 125-volt, single-phase, 15- and 20-ampere receptacles installed in bathrooms, kitchens, rooftops and outdoors, 6' from a sink, indoor wet locations, locker rooms, garages, service bays, and similar areas.
- All vending machines.
- All pool motors, spas, and pumps.
- All electric drinking fountains.
- Exceptions:
 - In industrial laboratories, receptacles used to supply equipment where removal of power would introduce a greater hazard shall be permitted to be installed without GFCI protection.
 - For receptacles located in patient bed locations of general care or critical care areas of health care facilities other than those covered under 210.8(B)(1), GFCI protection shall not be required.
 - Receptacles that are not readily accessible and are supplied by a branch circuit dedicated to electric snow-melting, deicing, or pipeline and vessel heating equipment shall be permitted to be installed in accordance with 426.28 or 427.22, as applicable.
 - In industrial establishments only, where the conditions of maintenance and supervision ensure that only qualified personnel are involved, an assured equipment grounding conductor program as specified in 590.6(B)(2) shall be permitted for only those receptacle outlets used to supply equipment that would create a greater hazard if power is interrupted or having a design that is not compatible with GFCI protection.

2.3. Condition of Use

If system is in abnormal physical condition, do not use.

Critical Errors

If power button is pushed ON and the unit does not turn ON, please plug in to grid power and allow to recharge for a minimum of 10h. If the unit does not turn ON, please contact HPS technical support for further assistance.

If internal components are heard/ believed to be loose inside/ rattling, please call HPS technical support.

3.1. Overview

The Batt Pack is an industrial, high performance, weather resistant lithium ion battery pack that is designed to be safe and easy to operate.

Designed to deliver the full potential of batteries by delivering 5000W of power. With an average life cycle of 8 to 20 years (depending on usage).

Idle consumption of the Batt Pack is between 40-70W when in standby mode and should be added to your run time calculations.

3.2. Technical Specifications of the Batt Pack Energy [POR0003]

Power	3,000W	Sine Wave	Pure Sine Wave
Surge Power	4,500W (500ms) 6,000W (10ms)	Output Voltage Threshold	5%
Loaded Motor Capacity	+2HP	Dimensions	60.5cm x 39.4cm x 33.6cm [23.8in x 15.5in x 13.2in]
Energy	2.5kWh	Weight	34.3 kg [75.6 lbs]
Chemistry	LiFePO4	Storage Temperature (with Polarshield)	-30°C to 50°C [-22°F to 122°F]
Cycles	+3,500 Cycles	Operating Temperature (with Polarshield)	-30°C to 50°C [-22°F to 122°F]
Voltage	120V AC*	Recharge Time	Grid = 2.5 Hours Solar= 2 Hour*** Alternator = 7 Hours
Frequency	60 Hz**	Idle Power Consumption	40W
Solar Input Power	1,600W	Humidity Range	5% - 95%
VOC Input Voltage	60V DC	Vibration Resistance	IEC 60068-2-64
Solar Input Voltage	30-80V DC	Shock Resistance	IEC 60068-2-31
Max Solar Amperage	40A	Output Efficiency	Greater than 90%
Grid Charging Power	1,200W	Certification	CE, UL9540A, UL1642, ESA SPE-1000, UL1741
Bypass Power	1,200W		
Safety Features			
Solar reverse polarity protection, overload protection, short circuit protection, surge protection, over temperature shut off			

*240V AC model for international version.

**50 Hz model for international version.

***With maximum solar power.

3.3. Technical Specifications of the Batt Pack Pro [POR0005]

Power	5,000W	Sine Wave	Pure Sine Wave
Surge Power	7,000W (500ms) 10,000W (10ms)	Output Voltage Threshold	5%
Loaded Motor Capacity	+3HP	Dimensions	64.7cm x 50.8cm x 30cm [25.5in x 20in x 11.8in]
Energy	5.1kWh	Weight	63.5 kg [140 lbs]
Chemistry	LiFePO4	Storage Temperature (with Polarshield)	-30°C to 50°C [-22°F to 122°F]
Cycles	+3,500 Cycles	Operating Temperature (with Polarshield)	-30°C to 50°C [-22°F to 122°F]
Voltage	120V AC*	Recharge Time	Grid = 4.5 Hours Solar= 1 Hour*** Alternator = 7 Hours
Frequency	60 Hz**	Idle Power Consumption	70W
Solar Input Power	5,500W	Humidity Range	5% - 95%
VOC Input Voltage	320V DC	Vibration Resistance	IEC 60068-2-64
Solar Input Voltage	120-320V DC	Shock Resistance	IEC 60068-2-31
Max Solar Amperage	40A	Output Efficiency	Greater than 90%
Grid Charging Power	1,400W	Certification	CE, UL9540A, UL1642, ESA SPE-1000, UL1741
Bypass Power	1,200W		
Safety Features			
Solar reverse polarity protection, overload protection, short circuit protection, surge protection, over temperature shut off			

*240V AC model for international version.

**50 Hz model for international version.

***With maximum solar power.

3.4. Technical Specifications of the Batt Pack series

	Batt Pack Energy	Batt Pack Pro
Power	3,000W	5,000W
Surge Power	4,500W (500ms) 6,000W (10ms)	7,000W (500ms) 10,000W (10ms)
Loaded Motor Capacity	+2HP	+3HP
Energy	2.5kWh	5.1kWh
Chemistry	LiFePO4	
Cycles	+3500 Cycles	
Voltage	120V AC*	
Frequency	60 Hz**	
Solar Input Power	1,600W	5,500W
VOC Input Voltage	60V DC	320V DC
Solar Input Voltage	30-80V DC	120-320V DC
Max Solar Amperage	40A	
Grid Charging Power	1,200W	1,400W
Bypass Power	1,200W	
Sine Wave	Pure Sine Wave	
Output Voltage Threshold	5%	
Dimensions	60.5cm x 39.4cm x 33.6cm [23.8in x 15.5in x 13.2in]	65cm x 50.8cm x 30cm [25.6in x 20in x 11.8in]
Weight	34.3 kg [75.6 lbs]	63.5 kg [140 lbs]
Storage Temperature (with Polarshield)	-30°C to 50°C [-22°F to 122°F]	
Operating Temperature (with Polarshield)	-30°C to 50°C [-22°F to 122°F]	
Recharge Time	Grid = 2.5 Hours Solar = 2 Hour*** Alternator = 7 Hours	Grid = 4.5 Hours Solar = 1 Hour*** Alternator = 7 Hours
Idle Power Consumption	40W	70W
Humidity Range	5% - 95%	
Vibration Resistance	IEC 60068-2-64	
Shock Resistance	IEC 60068-2-31	
Output Efficiency	Greater than 90%	
Certification	CE, UL9540A, UL1642, ESA SPE-1000, UL1741	
Safe Features	Solar reverse polarity protection, Short circuit protection, Over temperature shut off, Overload protection	

*240V AC model for international version.
**50 Hz model for international version.
***With maximum solar power.

3.5. Batt Pack Energy General Dimensions

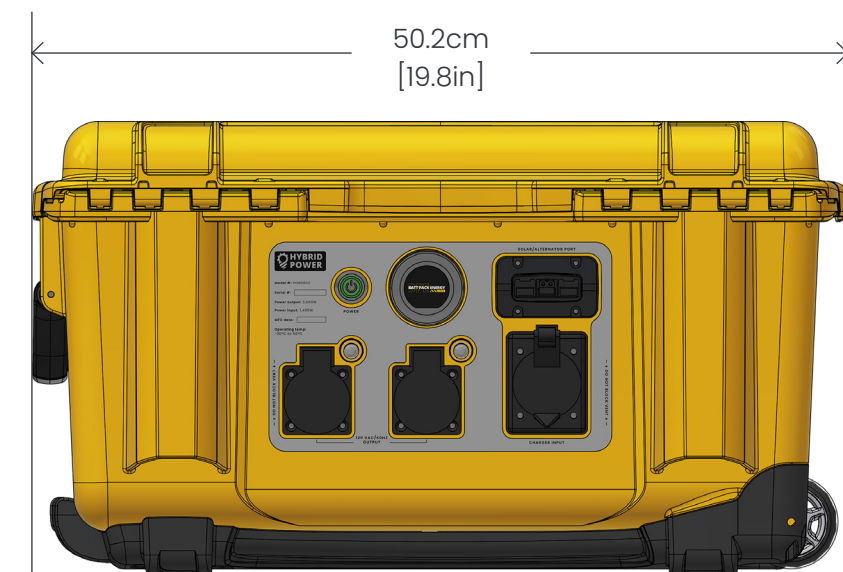

Appearance may deviate slightly due to ongoing innovation.

3.6. Batt Pack Pro General Dimensions

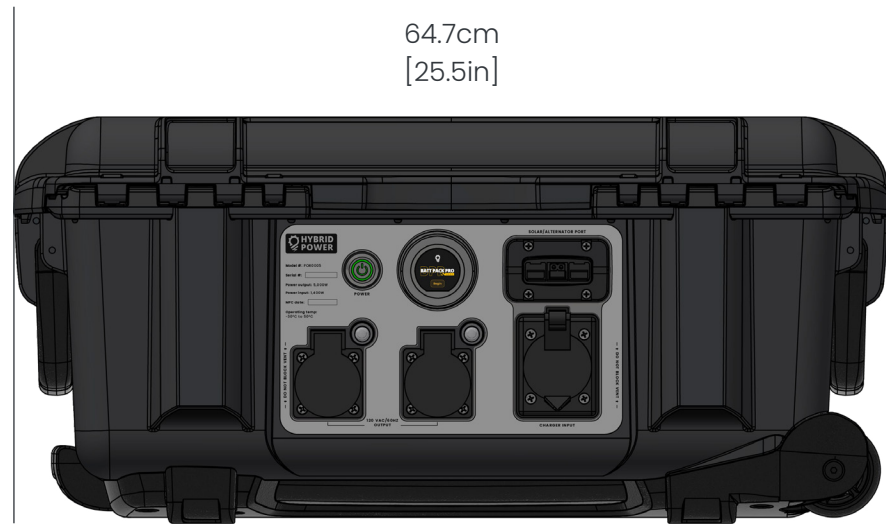

Appearance may deviate slightly due to ongoing innovation.

3.7. Batt Pack Control Board & Settings

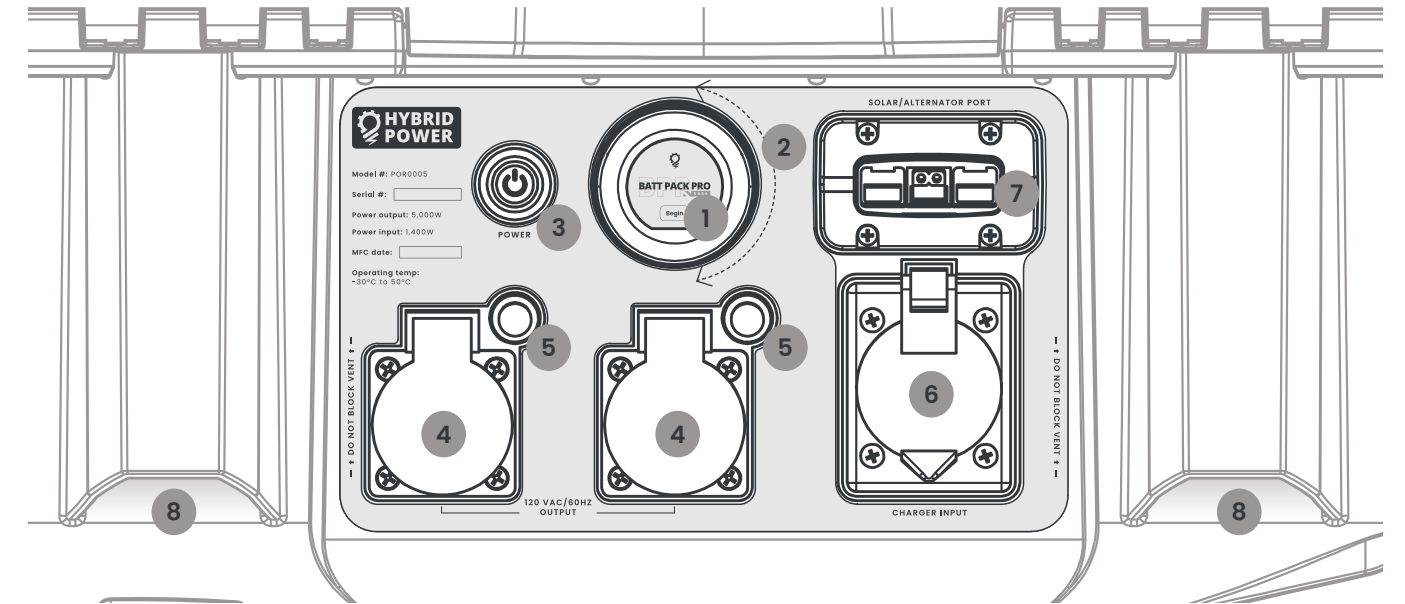

Indicator	Product Details
1	Touchscreen Display
2	Control Knob
3	Power Switch
4	Output Port
5	Circuit Breakers
6	Input Charge Port
7	Solar/Alternator Port
8	Ventilation Opening

3.7.1. Functions and display

Welcome Screen





This screen will appear when the unit is turned on. Press "Begin" to continue. You can access the other screens by turning the control knob left or right.

Charging Screen



The charging screen shows the power inputted to the Batt Pack from the charging port.



← Screen mode

← Charging current shown in Kilowatt

← Unit indicator

Actual screen configurations may change after software updates.

Battery State of Charge Screen



The Battery State of Charge Screen shows the level of charge of the Batt Pack by selecting the "%" symbol, and also shows the number of cycles used by selecting the "♻️" symbol

Battery cycles are based on the abuse level equivalent to a full discharge and charge.

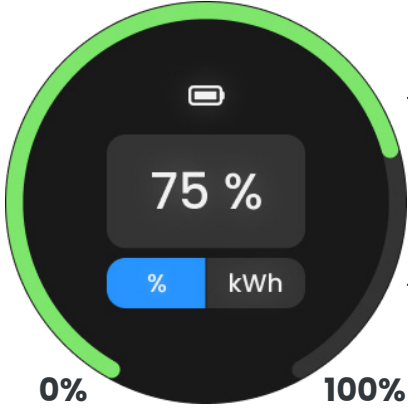

← State of Charge wheel

← State of charge shown in percentage

← Option selector. Battery state of charge selected

Battery Output Power Screen



This screen shows the amount of power the Batt Pack is supplying to the connected device.



← Screen mode

← Output power shown in Kilowatt-hour

← Unit indicator

Actual screen configurations may change after software updates.

Battery Temperature Screen



The Battery Temperature Screen shows the temperature of the Batt Pack in °C and °F using the temperature unit selector.

When using the Batt Pack in cold temperatures (<-0°C [32°F]), expect the battery to deplete faster than under room temperature environments. This is mainly due to the heating blanket using an average of 50W of power in a -30°C [-22°F] environment.

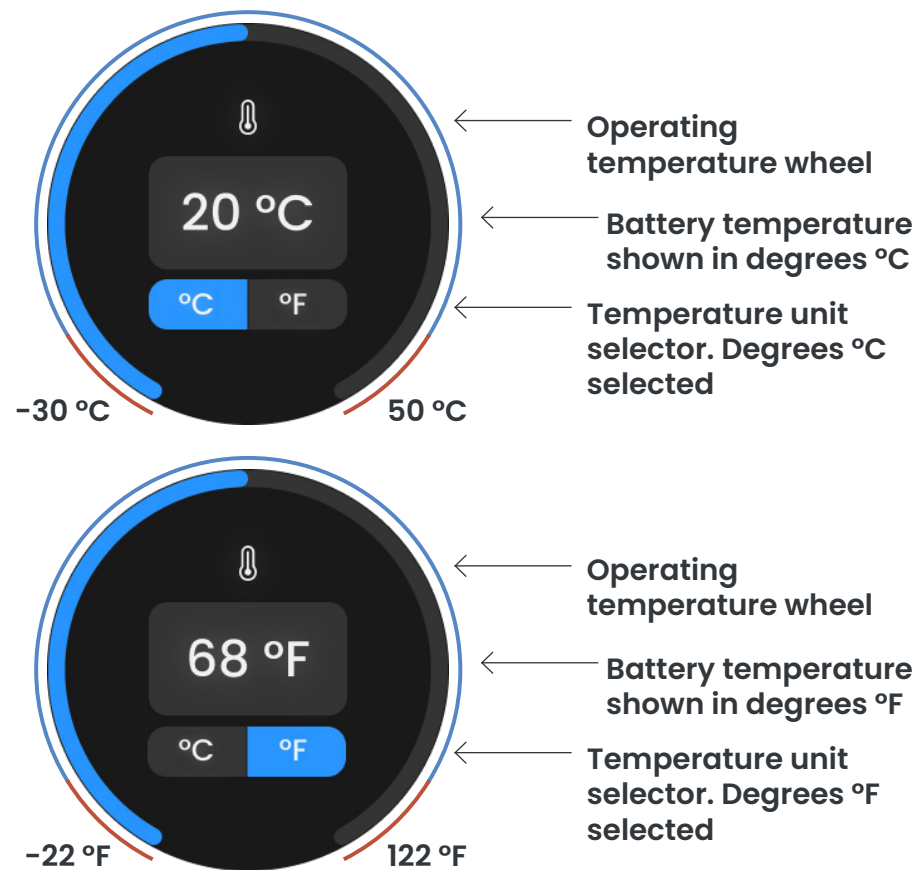

Actual screen configurations may change after software updates.

3.8. HPS Provisioning App Configuration

The HPS Provisioning App enables the owner to monitor the status and operating information of the Batt Pack through a periodically transmitted Wi-Fi communication system. This system allows the owner to monitor the Batt Pack status from anywhere as long as there is a stable Internet connection.

The HPS Provisioning App requires a one-time activation process. This activation process will also serve as product registration. For activation instructions, refer to section 3.8.1 Setup Wi-Fi, after a successful Wi-Fi setup follow the instruction in section 3.8.2 Visualize Data to access the data of the Batt Pack Unit.

3.8.1 Setup Wi-Fi

1. Open HPS Provisioning App
2. Scan the QR code provided with the Batt Pack (Make sure to be in the proximity of the unit as the app uses Bluetooth to communicate) **or** 2. Search for the Batt Pack via Bluetooth by selecting "I don't have QR code" and Select "BLE" for device Type. The unit will pop up under the device list in the format PROV_*****
- 2.1 Select the device and enter the pin: "abcd1234"
3. Choose the Wi-Fi from the list and enter the ssid
4. Press "Provision" to send Wi-Fi credentials to the Batt Pack

3.8.2 Visualize Data

5. Go to <https://portal.hybridps.ca>
6. Login with email and password (or create a new account by pressing Sign up)
7. Go to settings and add new device
8. Enter the serial number of the device and the password provided
9. If the device was registered with success you should see the data displayed in the home page.

3.8.3 Functions and Data Visualization

The HPS Provisioning App allows the owner to monitor the following parameters:

- Voltage
- Current
- Battery SOC
- Pack Amp/hours
- Pack Health
- Total Cycles
- Temperature
- System SOC
- Total System Current
- Connected Strings
- System Power
- Time to Charge
- Time to Discharge

Functions and appearance may change after the publication of this manual due to ongoing innovation. Please refer to the manual on our website for the latest edition.

The HPS Provisioning App enables the owner to access a condensed visualization for quick monitoring. The symbol "🕒" indicates the date and time of the last data update provided by the Batt Pack. This system allows multiple units to be registered for simultaneous monitoring. The owner can switch between units by choosing between the "Devices" drop-down menu.

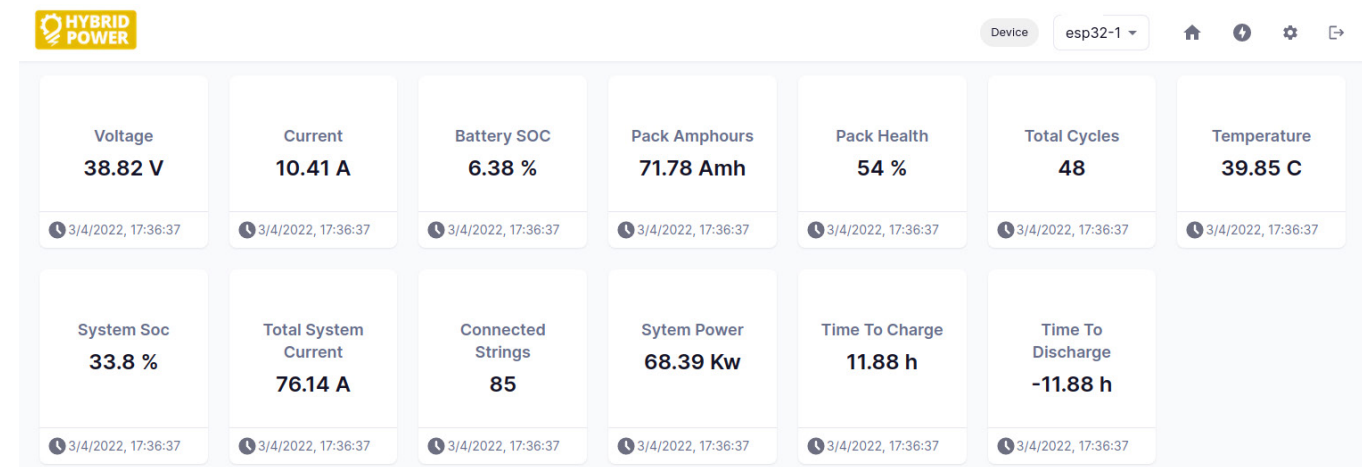

The HPS Provisioning App also enables a graph visualization for more in-depth monitoring through a specific period which the owner can adjust.



Functions and appearance may change after the publication of this manual due to ongoing innovation. Please refer to the manual on our website for the latest edition.

3.8.4 Configuration

The HPS Provisioning App enables the registration of multiple units for simultaneous monitoring. Under the “Devices” screen the owner can add a new unit or remove an existing unit. The owner can also see the date and time of the last data update of each registered unit.

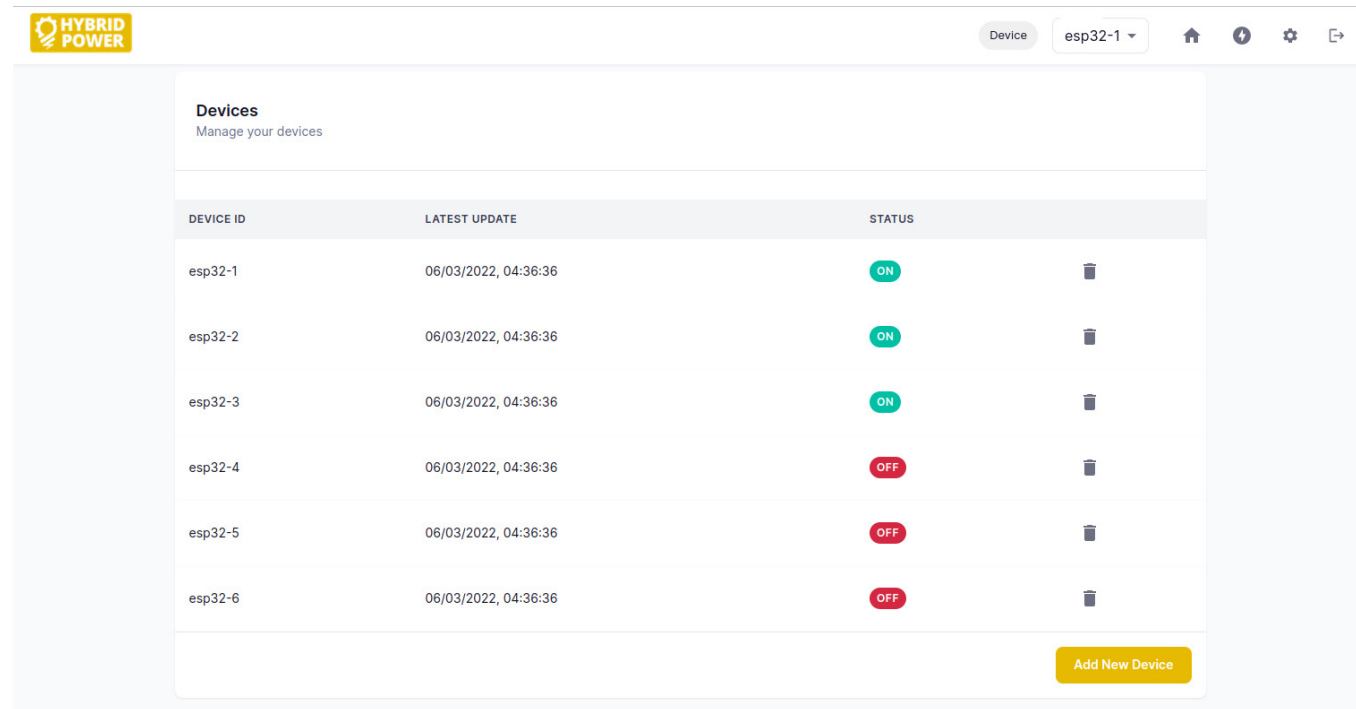

Note: While Hybrid Power Solutions has made all efforts possible to protect user data, it is imperative to take all necessary measurements to secure the connection. **We recommend a strong password to protect your personal data.**

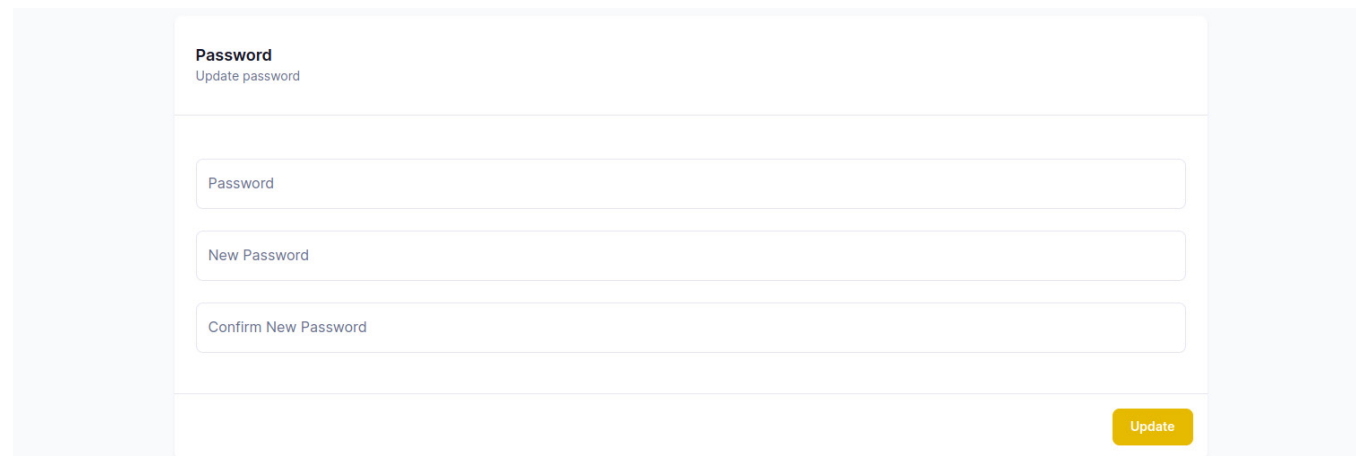

Functions and appearance may change after the publication of this manual due to ongoing innovation. Please refer to the manual on our website for the latest edition.

4.1. Component Identification and General Operation



*image may defer from actual unit based on product version and is subject to change at any time.

The plug cover should always be used to protect the plug from corrosion and other environmental factors.

The system should always be left in the OFF position when not in use. In the ON position, very little power is consumed but will slowly deplete the battery. HPS recommends always turning off the Batt Pack when not in use.

When using the system in cold temperatures (below 0°C), discharge power may be limited and run time can be affected by up to 40%. The Batt Pack includes our Polarshield protection when using the system in sustained temperatures lower than 0°C [22°F] and will keep the battery warm.

The Batt Pack will not allow a discharge to occur after being fully depleted until the system has been charged passed 10%.

Battery Depletion – If the unit is left in the ON position, standby power will be drawn and slowly deplete the unit. This is especially dangerous when the pack has been fully depleted. Please ensure that the unit is charged after having been depleted.

The unit should be charged at a minimum interval of 3 months. Please note that the gauge will not show any reduction in energy level, even though a minor discharge did occur.

A monthly self discharge of 5–10% will occur and may damage a unit that has been left stored after being depleted.

Just as a car battery will be depleted and need to be replaced after prolonged storage with no charging, the Batt Pack will do the same. Always ensure that you charge the product after use and turn the unit off. A battery stored fully discharged may permanently damage the product. **HPS is not responsible for batteries left depleted and these will not qualify for a warranty replacement.**

WARNING: Do not plug in tools requiring in excess of 20A into the plug. This can cause; damage, shock, injury and/or death. Please use caution when operating tools in wet conditions as this may lead to electrical shock, injury and/or death. HPS is not responsible for damaged or faulty equipment that has been plugged into the Batt Pack and has caused an incident.

Using the Batt Pack as a UPS (uninterrupted power source): Always ensure the power button is left in the ON position and the charging port is connected to a main power source (15A circuit minimum). Plug all loads into the output port. This will ensure that if the power from the mains is interrupted, your devices will not be affected.

WARNING: Always use appropriately sized extension cords and power bars that meet the requirements of your specific application.

Circuit Breakers: Located on the front of the Batt Pack are two (2) circuit breakers rated at 20A. These breakers will protect users and equipment from short circuits and power draws over 20A. To reset these, press in firmly.

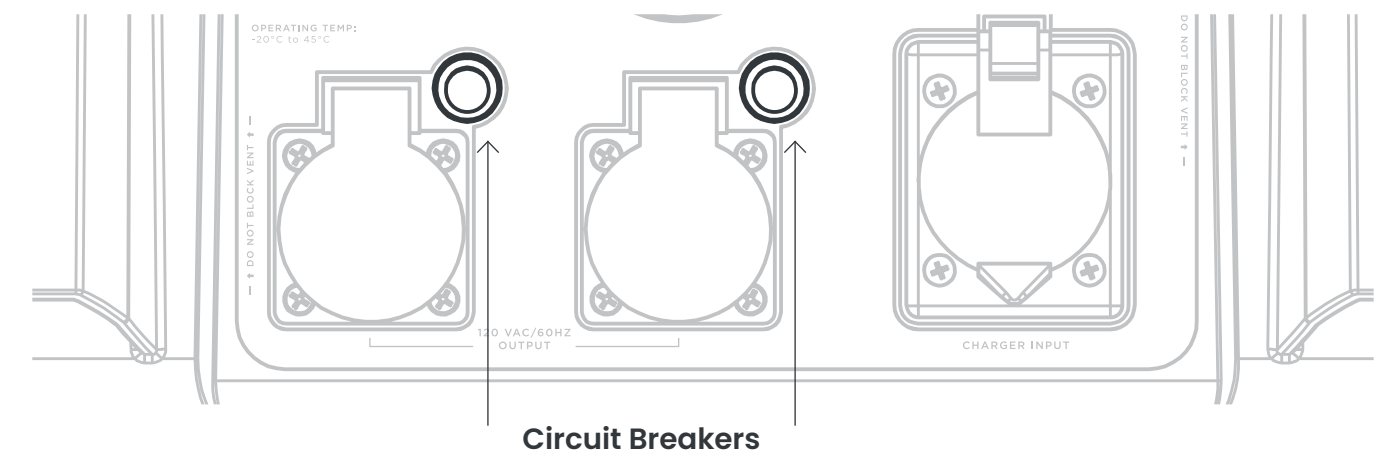

4.2. Break in Period

WARNING: Although the battery system is delivered balanced, below advertised performance may be present during the first 5 cycles (charge and discharge). As the cells in the battery module equalize to within +/- 0.01V. This is completely normal and is the nature of Lithium ion batteries. Use the unit as normal but do acknowledge this break in period.

Ideally during this break in period, HPS recommends the unit be charged to 100%, then left on the charger for +2 hours afterwards. This will give the cells a chance to balance in order to achieve optimal performance. We also recommend not to discharge past 25%. This recommended break in habit is to insure optimal performance as quickly as possible.

Not following this break in recommendation will not damage the system but will lead to an error. As the system will acknowledge the imbalance. It may also delay achieving peak performance.

4.3. Recharging Guide and Storage

Charge using a regular single ended extension cord rated for 15A minimum. Always charge the unit on a dedicated electrical circuit. HPS recommends a minimum 12AWG extension cord. Do not use adapters for charging purposes and do not run the extension cord off of a power bar.

After the break in period concludes, charge and discharge as desired.

Charge Batt Pack within 72 hours of complete discharge with power button off.

Charge a minimum of once a month in order to ensure the energy level does not fall to damaging levels.

It is safe to leave the Batt Pack plugged into the charger for extended periods of times as long as the power button has been turned OFF.

The battery can be charged with the power button either ON or OFF. We recommend keeping the system in the OFF position when not being discharged, as an energy saving practice.

4.4. Transporting and Shipping

If shipping units is required, please ensure to list the Batt Pack with your shipper as a hazardous goods and follow all required precautions and regulations. The Batt Pack is a UN38.3 certified, class UN3481 (lithium ion battery in equipment). It is the shipper's responsibility to ensure all paperwork and required packaging is in order. HPS can help guide you through the process.

4.5. Maintenance & Cleaning

WARNING: HPS does not recommend using a pressure washer to clean the unit as this may damage the internal components and void the warranty. Always make sure to turn OFF the unit when not in use and to keep the unit in a charged state

Always make sure to turn OFF unit when not in use and to keep the unit in charged state.

No user maintenance is required. Periodic system checks can be performed by an authorized HPS representative.

4.6. Extreme Temperatures & Fan Operation

WARNING: Using the product in extreme temperatures, above 50°C and below -30 °C may reduce the total life cycles of the product. **The warranty does not cover such usage.**

Note that performance may be affected in temperatures under 0°C. Run time can be reduced as well as available power.

To improve performance in cold weather scenarios, HPS suggests storing and charging the system at room temperature before exposing to cold temperatures. **Fans operate when the internal temperature of the system is higher than 29°C. This generally occurs in warmer climates and when the battery is being charged or is being discharged at a high-power output.**

4.7. Starting Motors

Please exercise caution when powering motors with the Batt Pack. Most motors require 2-3 times their continuous operating amperage at start-up. Certain motors may require more amperage than can be produced. Note that the surge power of 10,000W is only sustained for 10ms and may not be long enough for some motors. Motors with a soft start feature may help to reduce this inrush current.

Please note that Hybrid Power Solutions Inc. is not responsible for damaged tools, equipment or electronics.

4.8. Dusty Environment

In dusty environment, please use additional filters that can be ordered via Hybrid Power Solutions' products on our website, hybridps.ca

This filter is to be inserted in the main air intake. **It should only be used in dusty location and removed afterwards.**

This filter lowers the cooling efficiency of the unit and should only be used when dust is present in the air. After use, wash with warm water and let dry for a minimum of 24 hours.

5.1. Solar Panel Purchasing Guide

What you will need:

	Batt Pack Energy	Batt Pack Pro
Maximum total panel power	1,600W	5,500W
Panel Voltage	30-60V DC	125-320V DC
Recommended Wire Gauge	10AWG	
Connector Type	MC4	

5.1.1. How to choose cable

Cable selection is based on required distance from panel to Batt Pack. All 10AWG Solar Extension Cables with a MC4 connection are compatible with the Batt Pack. Please ensure you purchase a pair of cables; 1x for positive and 1x for negative.

Please minimize cable length to ensure minimal voltage drops.

5.1.2. How to choose your panel

The panel size should be based on power you will consume over a 24h period. You can work this out by multiplying the rated power of the equipment you are using, by the amount of time it is to be used in a 24h period.

Example:

Equipment: 1 computer, 1 LED light, 1 LED 32" TV

Computer: 8h of operation at 50W	= 400Wh
LED Light: 24h of operation at 12W	= 288Wh
LED 32" TV: 3h of operation at 55W	= 165Wh
TOTAL	= 853Wh consumed in 24h

Approximate amount of hours of sun: 8h

Solar Panel Wattage Required = (Wh Consumed / hours of sun) / 0.6*

Solar Panel Wattage Required = (853 / 8h) / 0.6 = 178W

*This value corrects for solar charger inefficiencies and other losses.

Therefore, we would recommend 200W of solar panels for this specific situation (2x100W). Note that some devices may not run at their rated power, such as tools. These likely operate at a much lower average power draw (2/3 of the rated power can be used). Also, appliances such as fridges may also be intermittent as the power is only drawn when cooling, which can be 10-40% of the time.

5.2. Solar Panel Wiring Guide

Warning: Please, note that the Batt Pack uses a high-voltage solar input that may cause electrocution and death. Please ensure a qualified electrician installs and wires solar panels to your Batt Pack following all local laws and regulations.

5.2.1 Standard Panel Connection with MC4 Y Connector

Connect both MC4 Y connectors to their respective ports on the Batt Pack.

Connect the solar panels to their respective MC4 Y connectors (Sold separately).

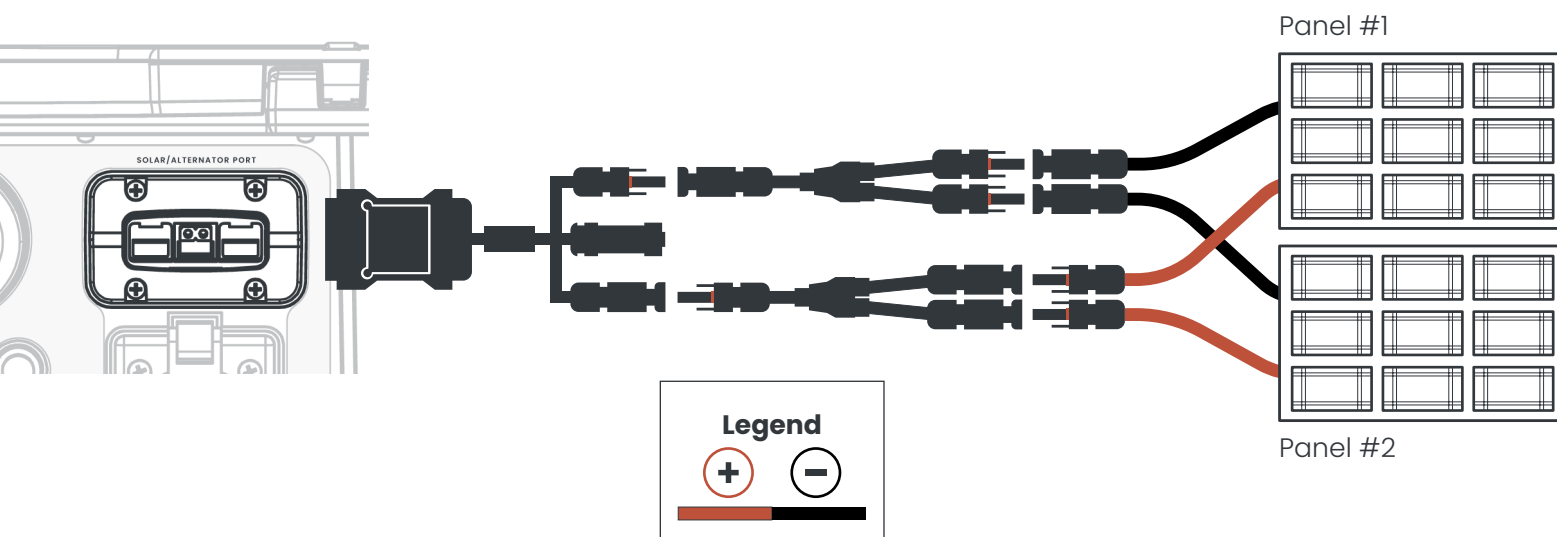

5.2.2. Batt Pack Energy Solar Panel Wiring Guide

Allowable input voltage: 30-60V DC

Maximum Power: 1,600W

Option 1. Folding solar panel (290/400W) & hard panel (300-500W): 38 & 60V DC

Option 2. Low voltage power (12/24V): 18V & 36V DC

A multimeter set to DC Voltage should be used to check panel voltage when exposed to sunlight to ensure the voltage is within the product specifications before plugging into the Batt Pack.

Option 1 = 1 Panel direct plug in

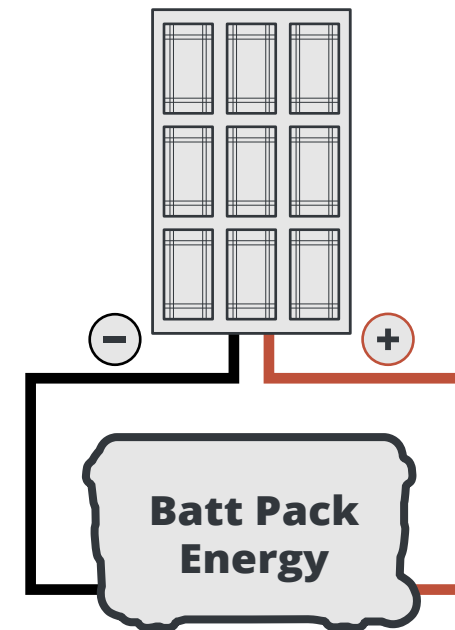

Option 2 = 2 Plugged in series

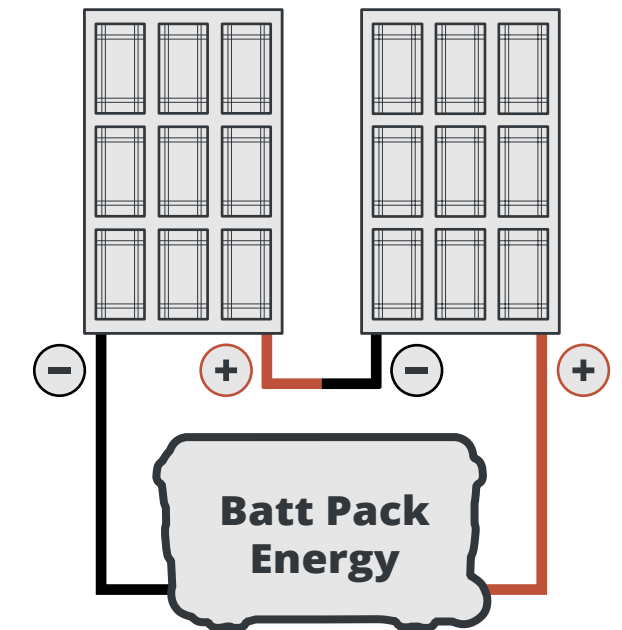

Option 1 (with multiple panels) = 2-6 panels (up to 1,600W) 1s1p, 1s2p, 1s3p, 1s4p...

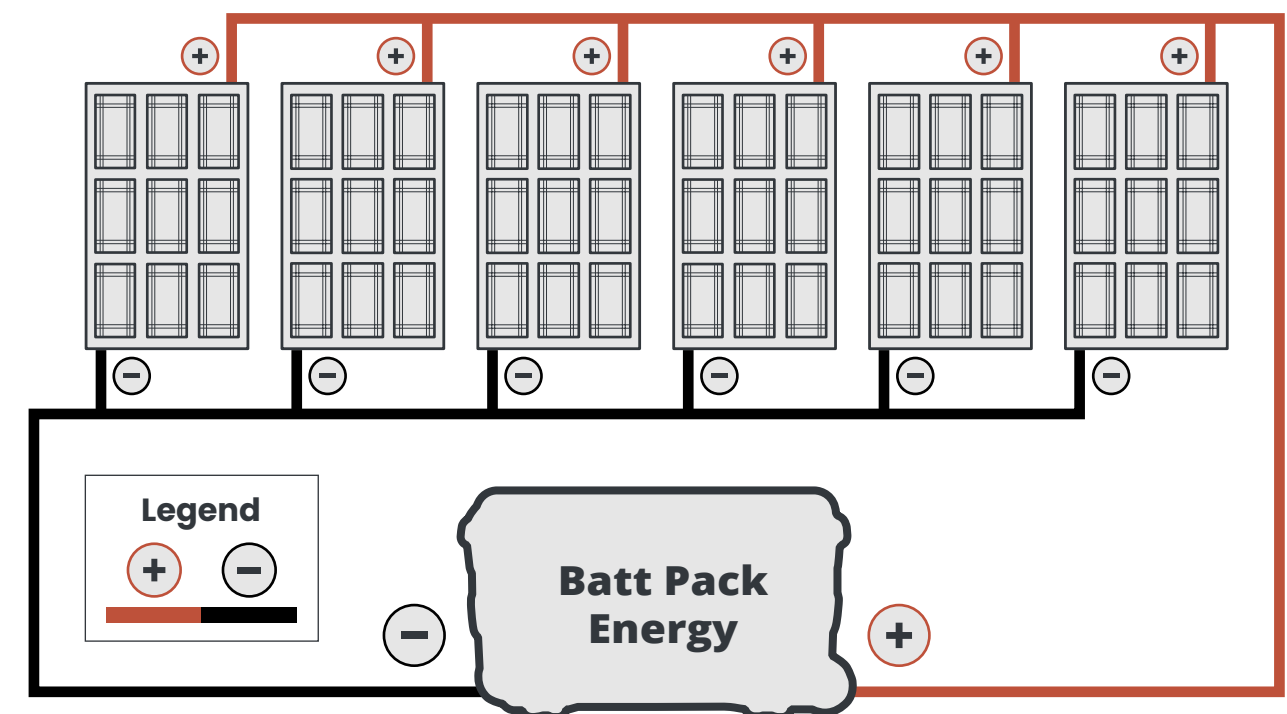

A multimeter set to DC Voltage should be used to check panel voltage when exposed to sunlight to ensure the voltage is within the product specifications before plugging into the Batt Pack.

5.2.3. Batt Pack Pro Solar Panel Wiring Guide

Allowable input voltage: 125–320V DC

Maximum Power: 5,500W

Option 1. Hard solar panel (300–450W): 38–60V DC

Option 2. Folding solar panel (290/400W): 60V DC

Option 1 = Hard Panels 3–12 panels. 3s1p 3s2p 3s3p 3s4p...

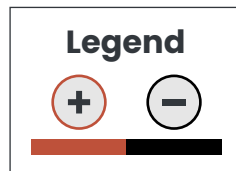
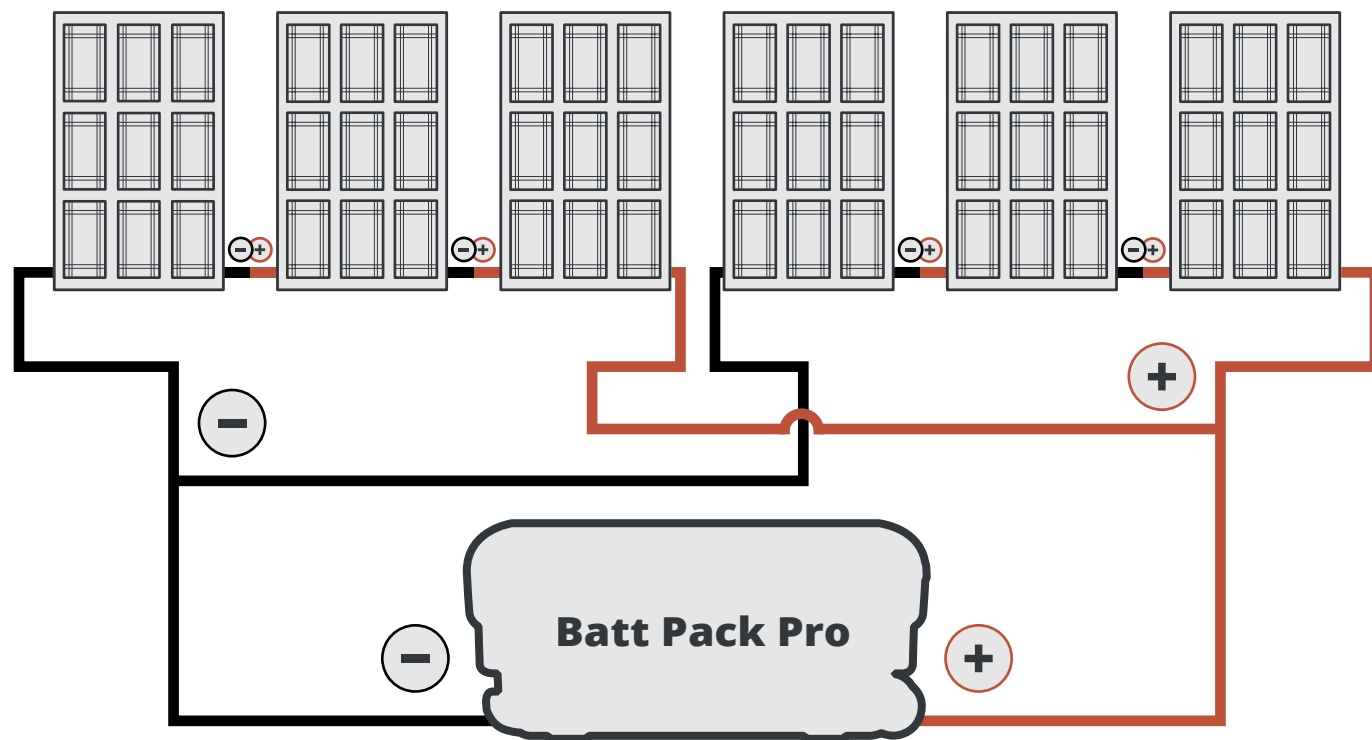

Option 2 = 2 in series and multiple pair in parallel. 2s1p 2s2p 2s3p 2s4p...

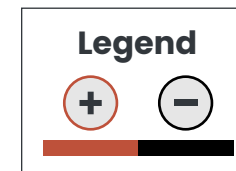
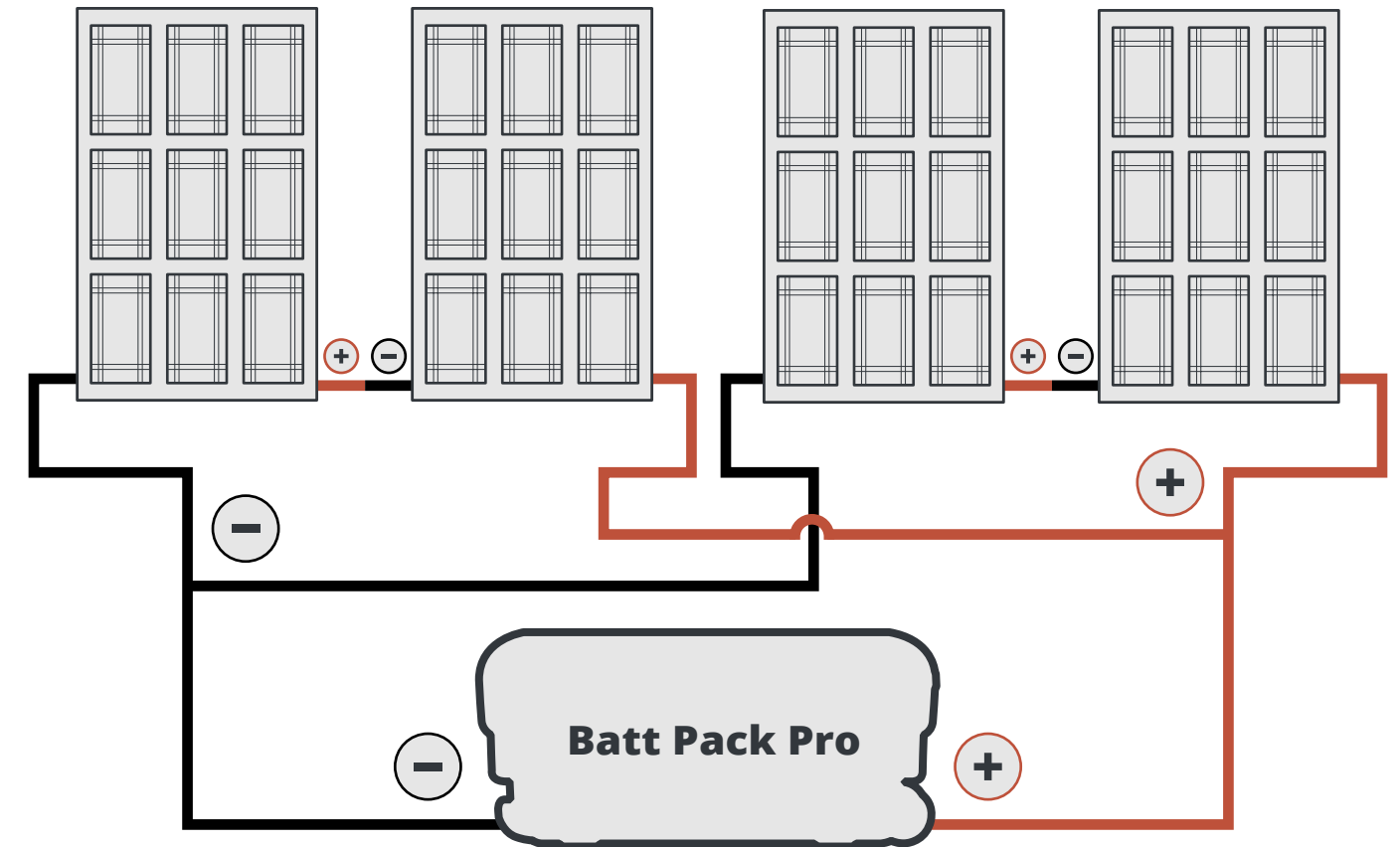

5.3 Combiner Box

A properly rated combiner box with shut off mechanism should be used for long-term/permanent applications. Check local electrical requirements and certification requirements to ensure they meet the local electrical code.

A multimeter set to DC Voltage should be used to check panel voltage when exposed to sunlight to ensure the voltage is within the product specifications before plugging into the Batt Pack.

A multimeter set to DC Voltage should be used to check panel voltage when exposed to sunlight to ensure the voltage is within the product specifications before plugging into the Batt Pack.

HARDWIRE INSTRUCTIONS FOR BACKUP POWER

Section 6

Recommended Automatic Transfer Switch (ATS): **Xantrex 8080915 PROwatt SW**

1. Chosen home circuit is disconnected from breaker source (input of breaker).
2. Breaker is feed (connected) to the AC Output of the Automatic Transfer Switch.
3. AC Input 2 from the Automatic Transfer Switch is connected to the main panel power source (Mains/Shore Power).
4. AC Input 1 from the Automatic Transfer Switch is plugged into the Batt Pack output port. No special tools or plugs required (see manual).
5. Dedicated extension cord is plugged into the Batt Pack Input (charger port) and unit is left ON.

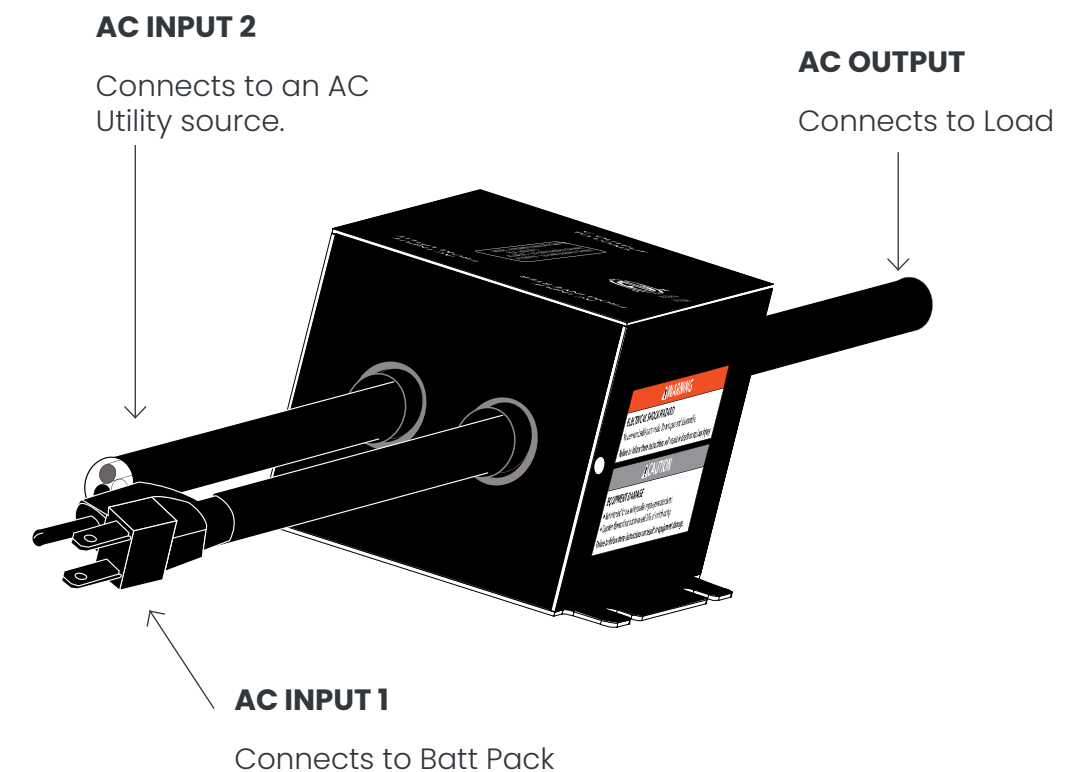

*Multiple ATS can be used to accommodate multiple home circuits up to Batt Pack maximum power threshold.

Hybrid Power Solutions Inc. is not responsible for any damage or injury/death that may occur from wiring its product. We do not represent Xantrex and make no claims on their behalf. Always use a trained and certified electrician when modifying electrical circuits.

7.1. Problem and Solution Table

Problem	Solution
Charger plugged in but unit not turning ON	<ul style="list-style-type: none">• Check to ensure power is live from extension cord
Audible warning is heard	<ul style="list-style-type: none">• Unit is low on energy. Recharge.• Power demand exceeds rated capacity. Reduce load.• Temperature of unit is too high, let unit cool down. Gauge backlight will be off as well.• Fault or Short Detected. Remove load immediately and inspect.
Switch ON but gauge is off and no power is being output.	<ul style="list-style-type: none">• Critical fault has occurred. Reset by turning system OFF for 120 seconds. Plug into shore power for charging. If the problem persists, connect unit via Wi-Fi to computer and check for any errors. Ensure unit is plugged in to charge during this process..

8.1. Technical Specifications – DC Charging

Power	850W
Input Voltage	12VDC*
Max Input Draw	65A
Suggested Disconnect	Battery isolator 80A minimum

*24VDC version available via special order.

8.2. Input Source

The alternator charging system allows for various DC inputs to charge the Batt Pack. The system will draw all available amperage up to 850W and is not current limited. It is therefore essential that the source has a current limiting device or allows for the maximum charging capability (up to 65A on 12V battery).

The following power sources are some examples of power inputs:

- 12V battery
- Vehicle battery connected to alternator
- Wind turbine with wind turbine charger (may not be compatible with all models)
- Solar charger (may not be compatible with all models)

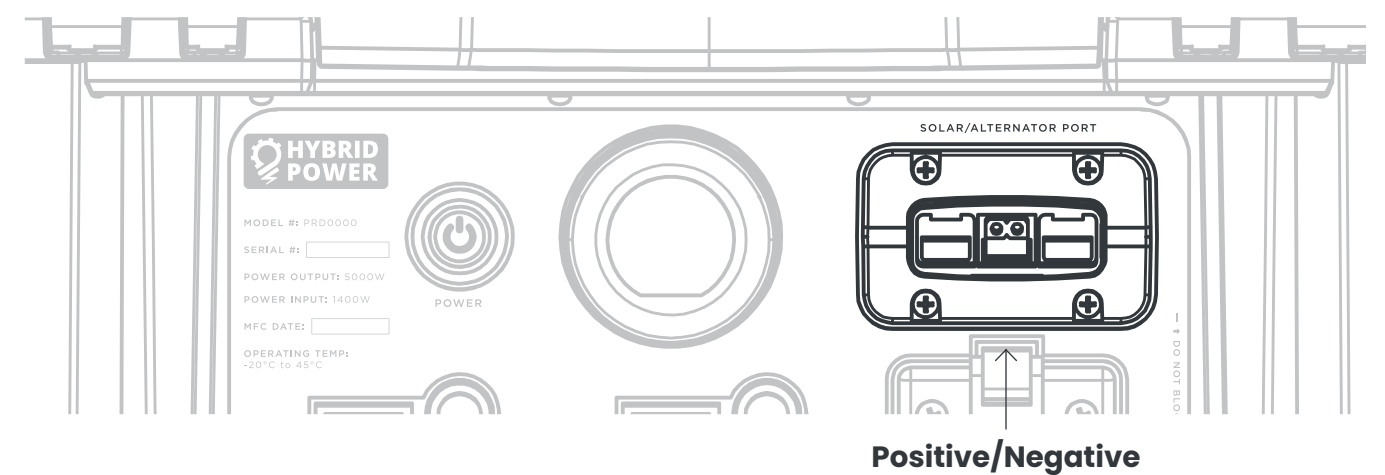

8.2.1 High Speed Vehicle Charger

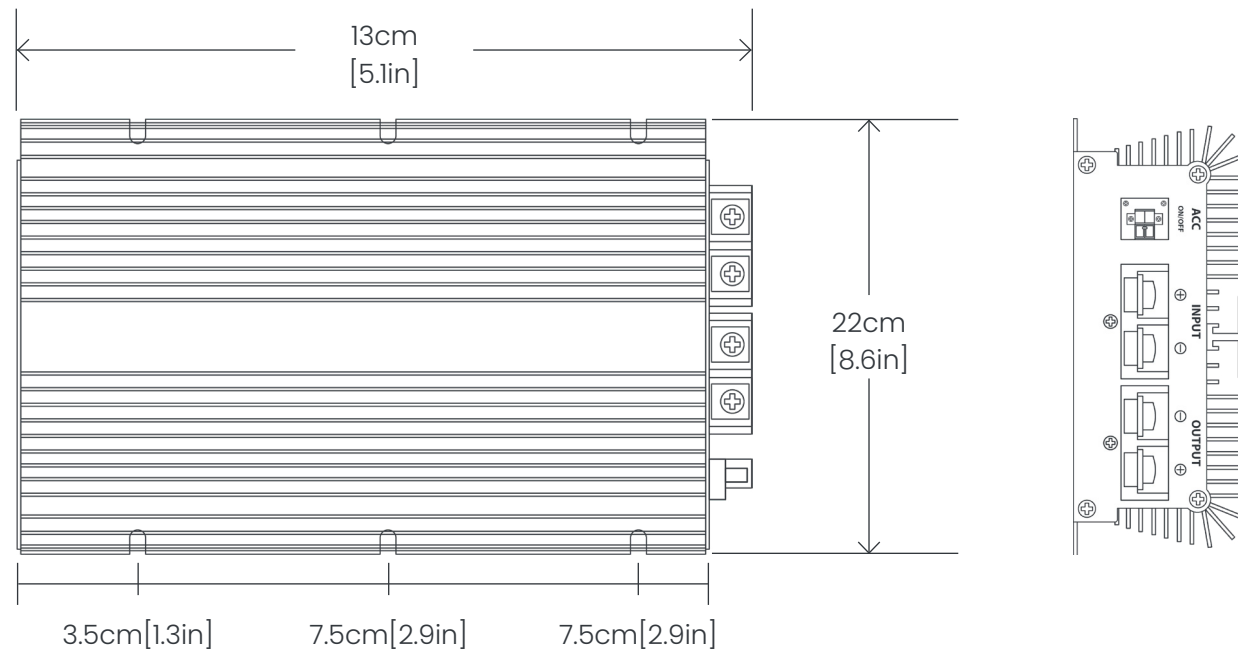

Charger Mounting Pattern

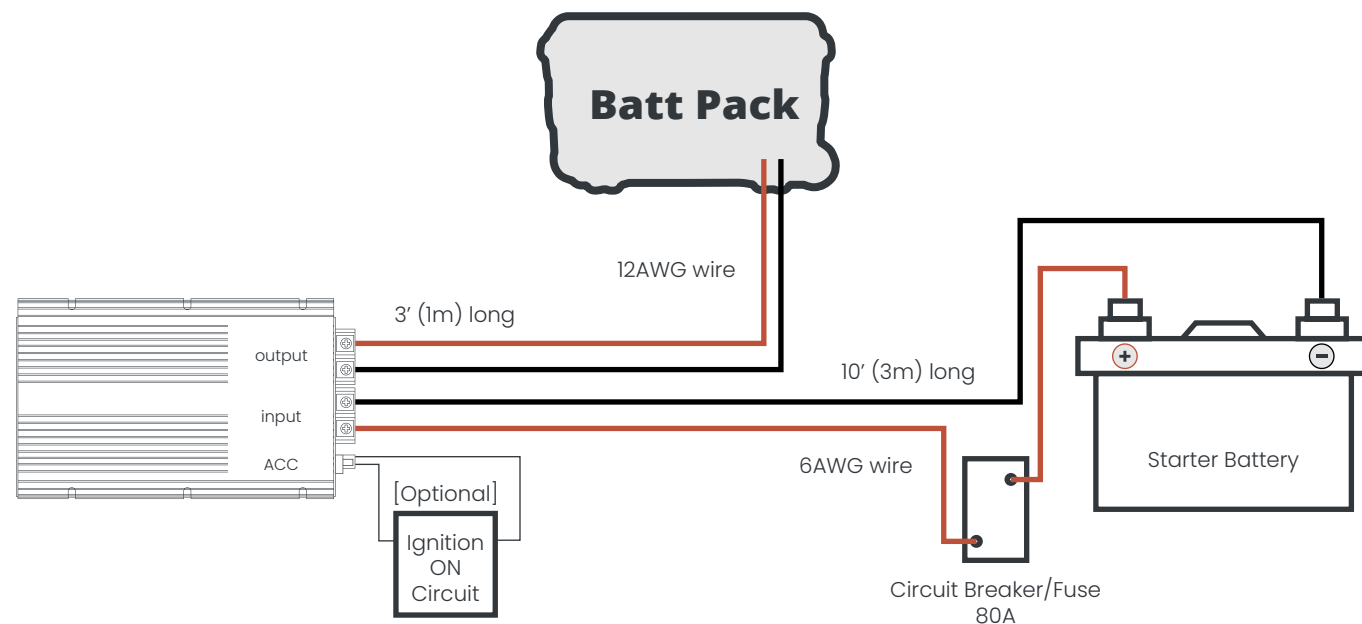

8.2.2 Vehicle Charger

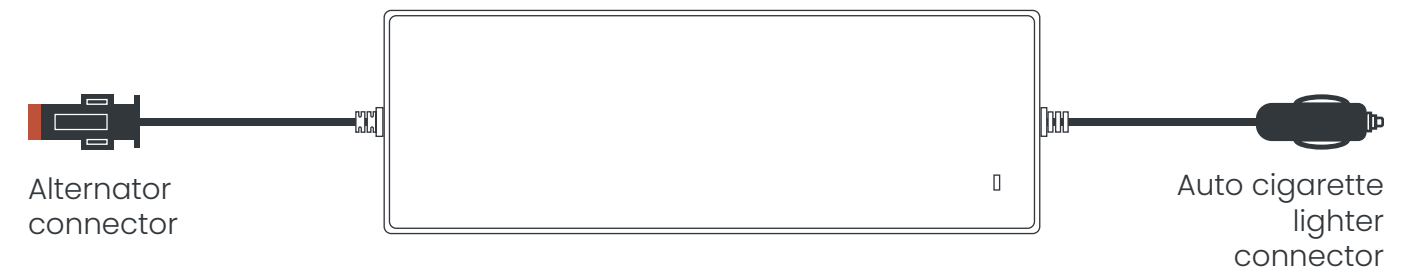

Charger Mounting Pattern

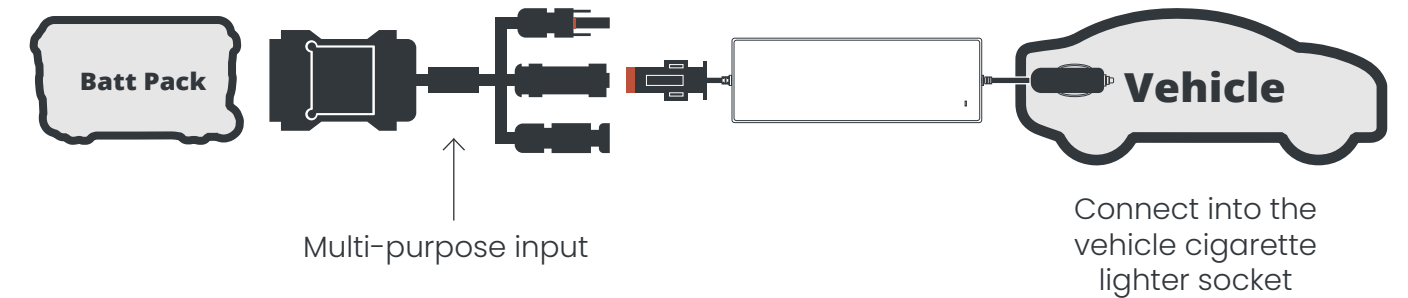

8.3. Fusing

A fuse is built into the cigarette lighter version of the vehicle charger. The fast charger has an external fuse included with the kit and should be used during installation. This ensures that the system is protected from a short circuit on the input wire. The fuse should be placed as close as possible to the input DC power source.

8.4. Source Low Voltage Protection

The charger is designed to stop charging when the vehicle is off but dependent on battery type and system configuration, this may not be the case for all situations. Adding an additional low voltage protection such as an isolator or solenoid provide an additional layer of protection. The ACC (accessory) circuit may also be used to turn ON and OFF the charger via an external switch or using the vehicle ON circuit (as shown on the "Charger Mounting Pattern" on page 44). HPS is not responsible for any damage caused to external inputs or power sources. If the minimum voltage threshold for the input battery is above 12V, a battery isolator should be used. Please see the diagram in the next section. A low voltage disconnect rated for the appropriate amperage may also be used.

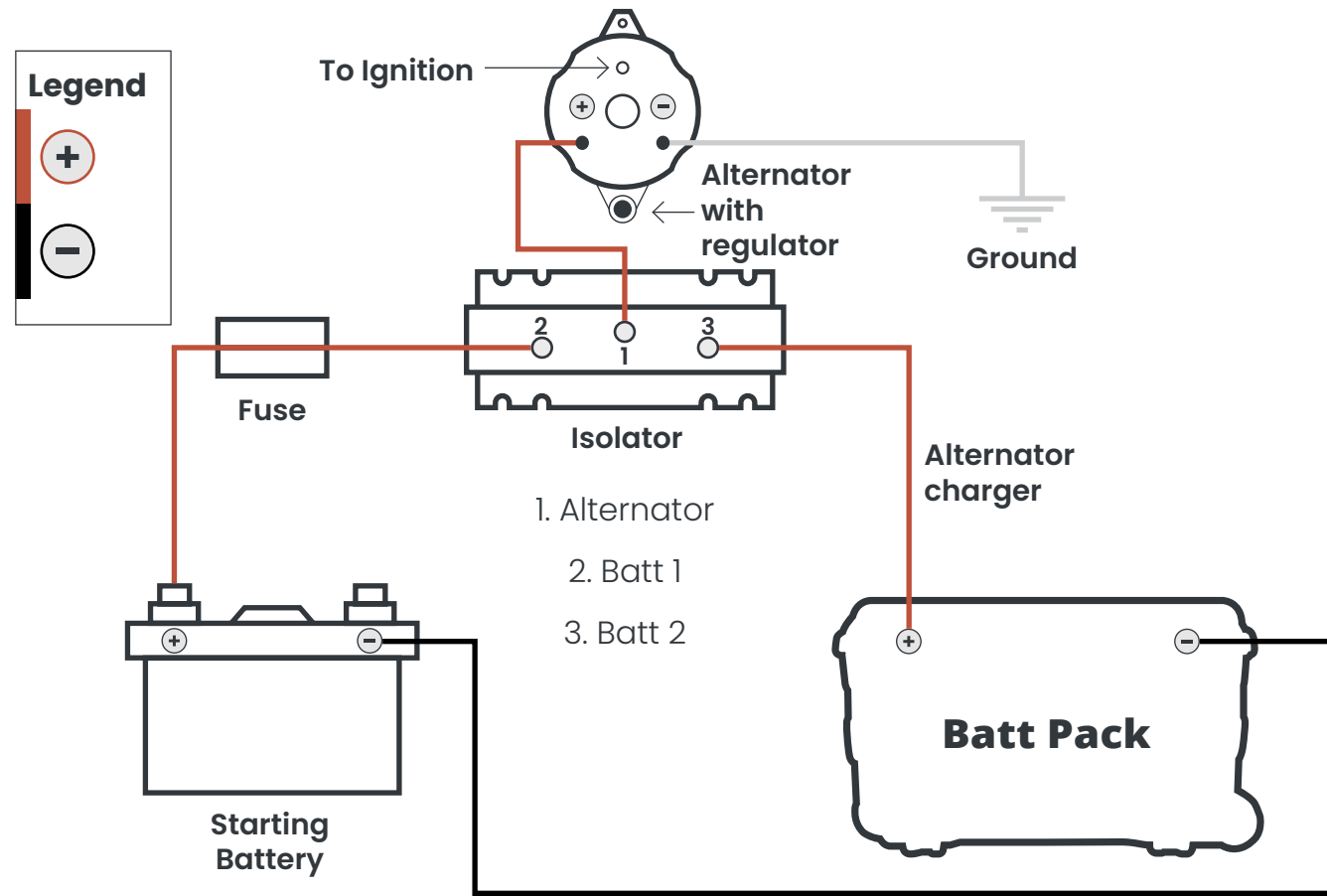

8.5. Battery Isolation

If the input source can be overdrawn by the Batt Pack, a battery isolator should be used to protect this input source. The following is the general wiring for a battery isolator, but specific instructions are provided by the chosen isolator manufacturer. This is an additional option to section 8.5

8.6. Combined Charging Methods

It is possible to charge the Batt Pack from multiple power sources. For example, the multi- purpose input as well as the standard wall charger may be used simultaneously. In this case, input from the wall charger may be limited if the battery temperature is elevated. In certain scenarios, the multipurpose DC input may be turned off when approaching the final steps of the battery charging process. The rapid charging process from combined source may lower the number of available battery cycles.

9.1. Manufacturer's Warranty Coverage

All Batt Packs supplied by Hybrid Power Solutions are tested for reliability and performance before delivery for correct function and condition.

We grant no warranty or liability for defects and losses that occurs during the use by the customer.

Please refer to this user manual to ensure proper user operation and operating conditions, which will ultimately prolong the life of the Batt Pack unit. The warranty does not cover negligence to this manual's directions.

Hybrid Power Solutions (HPS) warrants its products against defects in material and workmanship. Under normal use and service, every hardware portion of the product will be free from physical defects in material and workmanship during the warranty period, or the product will be repaired or replaced as determined solely by HPS. HPS provides a limited warranty for its products only to the person or entity that originally purchased the product from HPS or its authorized distributor or retailer.

9.2. Owner's Warranty Responsibility

If the product does not operate as warranted above during the applicable warranty period, HPS shall, at its option and expense (except for shipping cost), repair the defective product or part, deliver to the customer an equivalent product or part to replace the defective item. All products that are replaced will become the property of HPS. Replacement products may be new or reconditioned as determined by state of the original unit.

Standard warranty period (unless otherwise contracted) is 30 months.

9.3. Exclusions

Warranty does not apply, if

- The warranty period is expired,
- The warranty label is broken or removed,
- The serial number label is missing or unrecognizable,
- The product has been modified, opened or repaired by any unauthorized service center or personnel,
- The defect was subject to abuse, improper use not conforming to product manual instructions, or environment conditions more severe than those specified in the manual operating condition and user operation.

- The G Shock sticker has been triggered. (50G)
- The water tape indicator has been triggered.
- Low voltage incident.

9.4 Recycling

Please return the product to HPS for safe recycling. If the battery within the system is suspected to be damaged, please recycle at the closest electronics recycling facility.

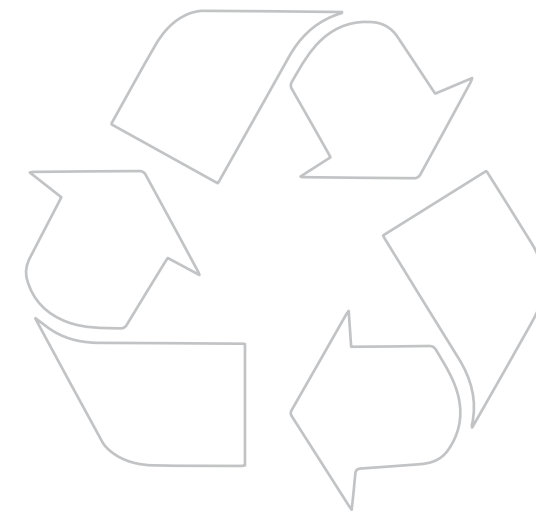

[This page intentionally left blank]

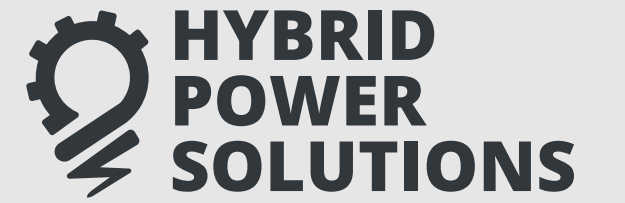

BATT PACK



**HYBRID
POWER
SOLUTIONS**